

HKS 700E

Service Manual

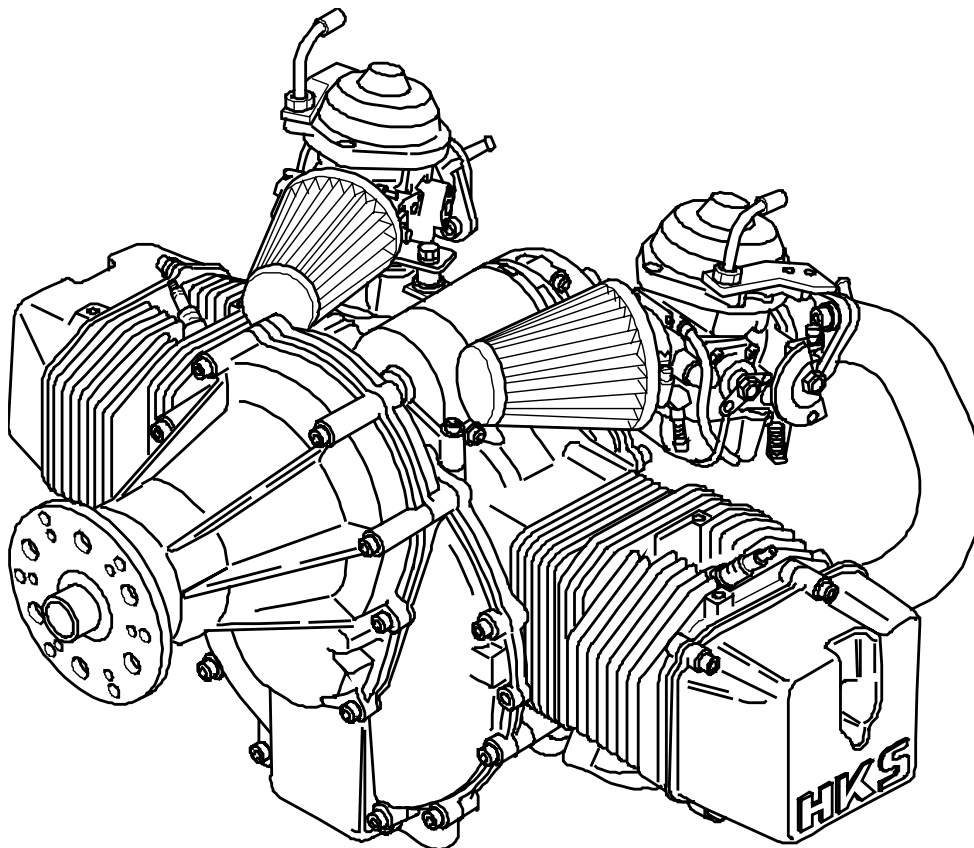

2005 November

Ver. 2.01

HKS CO.,LTD

7181 KITAYAMA FUJINOMIYA

SHIZUOKA

JAPAN 418-0192

TEL +81(0)544-54-1781

FAX +81(0)544-54-1410

hks_aviation@hks-power.co.jp

http://www.hks-power.co.jp/hks_aviation/

CONTENTS**PG1-3**

- 1 Introduction**
- 2 General information**
 - 2.1 Special tools**
- 3 Disassembly**
 - 3.1 Carburetor disassembly**
 - 3.1.1 Upper type**
 - 3.1.2 Horizon type**
 - 3.2 Intake manifolds removal**
 - 3.3 Electric starter removal**
 - 3.4 Spark plug removal**
 - 3.5 Gearbox removal and disassembly**
 - 3.5.1 A type (ratio 2.58)**
 - 3.5.2 B type (ratio 3.47)**
 - 3.6 Front cover removal**
 - 3.6.1 Drive gear removal**
 - 3.7 Rear cover removal and disassembly**
 - 3.7.1 Oil pump disassembly**
 - 3.8 Stator removal**
 - 3.9 Starter idler gear and Driven gear removal**
 - 3.10 Flywheel removal**
 - 3.11 Cylinder head removal**
 - 3.11.1 Cylinder head disassembly**
 - 3.12 Cylinder and Piston disassembly**
 - 3.13 Crankcase disassembly**
 - 3.14 Crankshaft disassembly**

4 Assembly

4.1 Connecting rod reassembly

4.2 Crankcase reassembly

- 4.2.1 Crankshaft Bearing and Thrust bearing**
- 4.2.2 Crankshaft**
- 4.2.3 Camshaft**
- 4.2.4 Oil strainer**
- 4.2.5 LH crankcase**

4.3 Piston reassembly

- 4.3.1 Piston ring**

4.4 Cylinder reassembly

- 4.4.1 Hydraulic lifter**

4.5 Cylinder heads reassembly

- 4.5.1 Push rod**
- 4.5.2 Rocker arm compartment**

4.6 Cylinder head cover reassembly

4.7 Flywheel reassembly

4.8 Driven gear and Starter idler gear reassembly

4.9 Rear cover reassembly

- 4.9.1 Stator**
- 4.9.2 Oil pump**
- 4.9.3 Pressure regulator**
- 4.9.4 Oil filter**

4.10 Front cover reassembly

- 4.10.1 A type (ratio2.58)**
- 4.10.2 B type (ratio3.47)**

4.11 Gearbox reassembly

- 4.11.1 A type (ratio2.58)**
- 4.11.2 B type (ratio3.47)**

4.12 Electric starter reassembly**4.13 Spark plug reassembly****4.14 Intake manifolds reassembly****4.15 Carburetors reassembly****4.15.1 Upper type****4.15.2 Horizon type****5 Table for torque values****6 Selection of metal bearing****6.1 Connecting rod bearing****6.2 Crankshaft bearing****7 Grading of cylinder and piston****8 Wear limits**

 **WARNING!**

This is a non-certified aircraft engine; the possibility of engine failure exists at all times. Do not operate this engine over densely populated areas. Do not operate this engine over terrain where a safe, power off landing cannot be performed.

The operating and maintenance instructions supplied with this engine must be followed at all times. Flying any aircraft involves the risk of injury or death, building and maintaining your own aircraft requires great personal responsibility.



1 Introduction

2 General information

2.1 Special tools

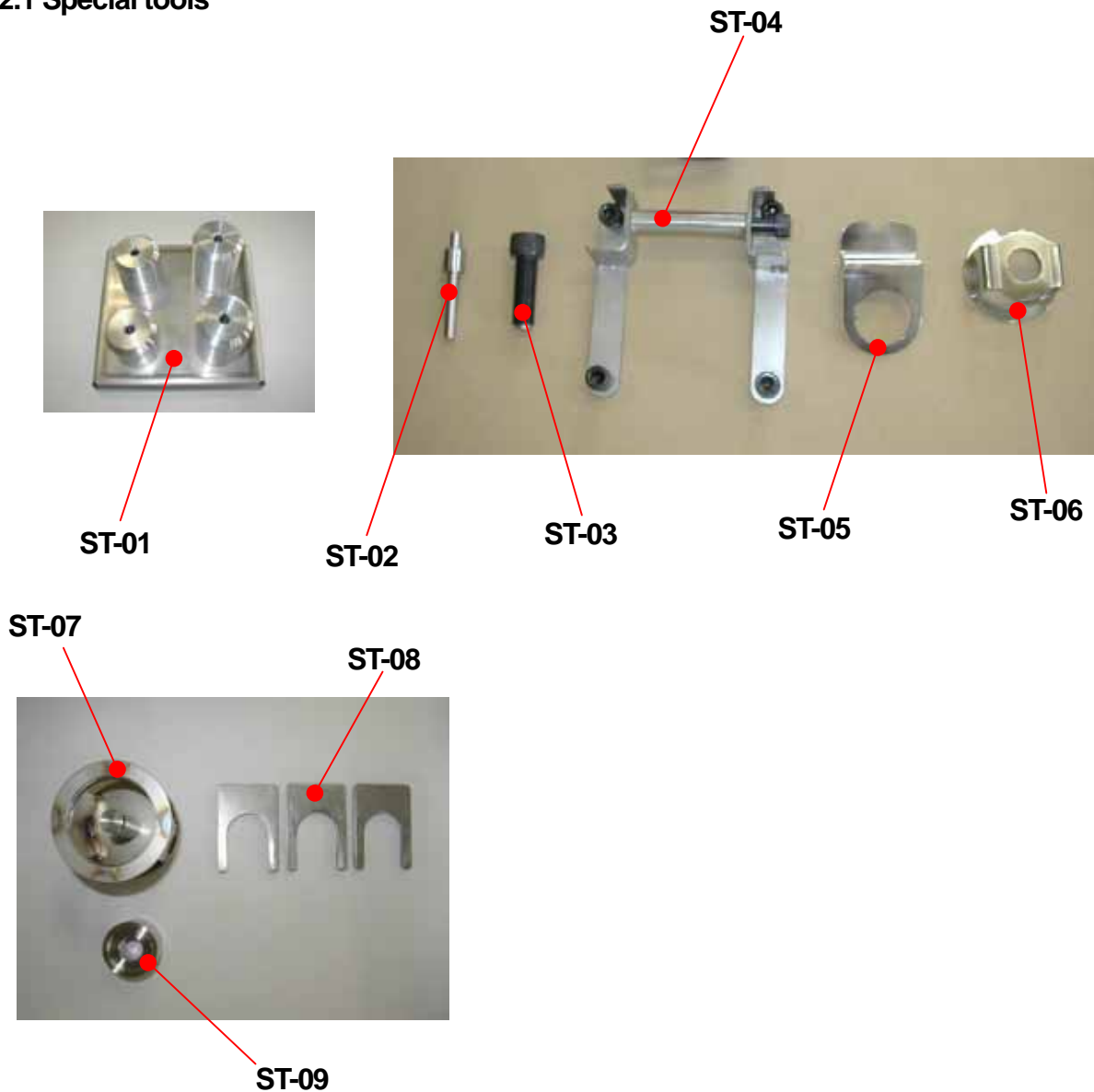

In addition to this service manual, please refer to the following.

- (1) HKS 700E Installation instruction Manual
- (2) HKS 700E Operations Manual
- (3) HKS 700E Parts List

3 Disassembly

3.1 Carburetors removal

NOTE: Identify both carburetors to RH/LH cylinders.

3.1.1 Upper type

- Remove 2 nuts M6.



3.1.2 Horizon type

- Remove tension spring.



- Loosen clamp screw and remove carburetor by turning action.



3.2 Intake manifolds removal

- Remove 2 bolts M8 and intake manifold.
- Remove intake gasket .

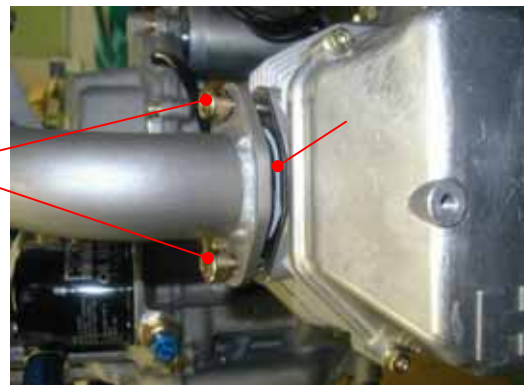

3.3 Electric starter removal

- Remove 2 bolts M6.
- Shift to remove electric starter.



3.4 Spark plug removal

- Remove 4 spark plugs.

3.5 Gearbox removal and disassembly

3.5.1 A type (ratio2.58)

- Remove 8 bolts M6.

3.5.2 B type (ratio3.47)

- Remove 10 bolts M6.

- Shift to remove gearbox.

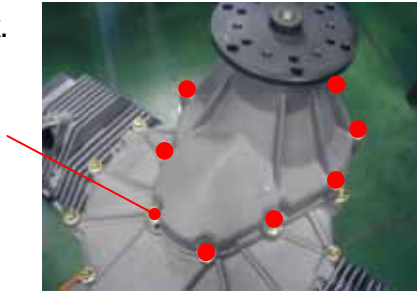

- Remove circlip .
- Set **ST-07** as shown.



- Compress gear and remove half rings .

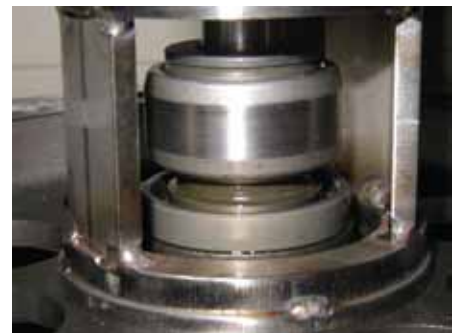
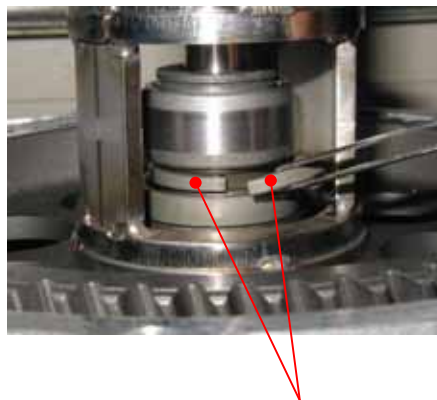

- Remove Inner race following below instruction..

STEP 1: Compress **ST-07** to make clearance between Inner race and Retainer.

STEP 2: Insert one **ST-08**.

STEP 3: Decompress **ST-07**. Inner race will move to upward by spring washers.

If three **ST-08s** are inserted, go to **STEP 4** else go to **STEP 1**.

STEP 4: Remove **ST-08s** and **ST-07**. Remove Inner race.

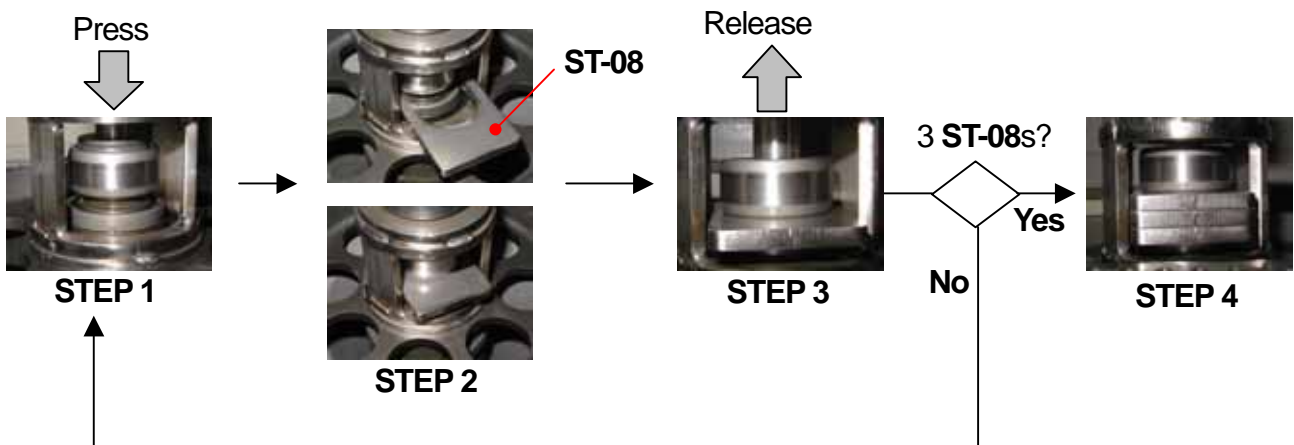

- Remove retainer.
- Remove gear , hub dog and spring washer .



- Remove spacer .



- Press PTO shaft to remove from gearbox.

3.6 Front cover removal

3.6.1 Drive gear removal

- Block crankshaft with **ST-02**.

ST-02

- Remove nut M25 and washer .
- Shift to remove drive gear .



- Remove 12 bolts M6.
- Shift to remove front cover.

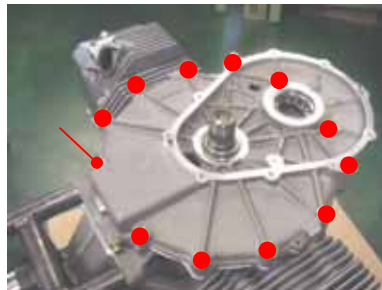

3.7 Rear cover removal and disassembly

- Remove oil filter with oil filter wrench.
- Remove 10 bolts M6.
- Shift to remove rear cover.

NOTE: Do not lose the thrust washer .

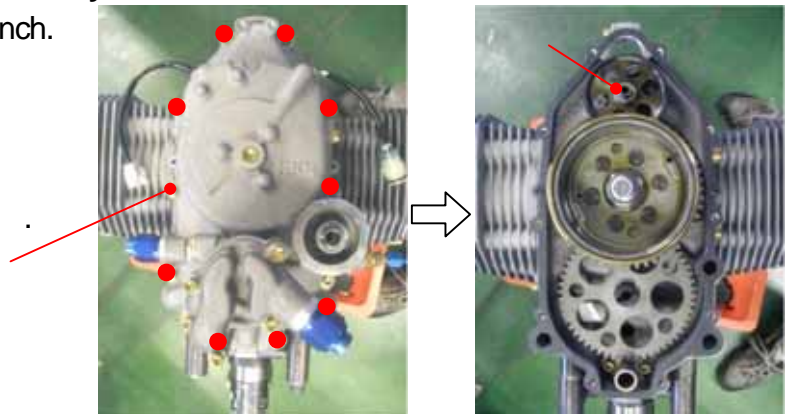

3.7.1 Oil pump disassembly

- Remove bolt .
- Remove spring and valve.



- Remove 5 bolts M6.
- Remove oil pump cover.

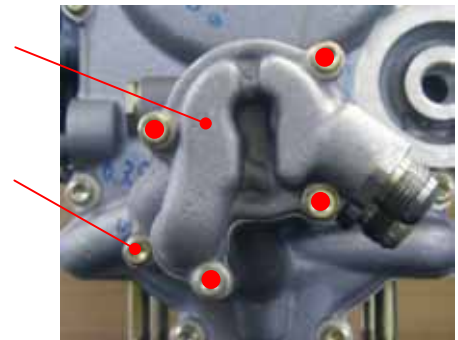

- Remove inner rotor (25mm).
- Remove woodruff key .
- Shift to remove pump body (25mm).



- Remove inner rotor (15mm).
- Remove woodruff key .
- Shift to remove pump body (15mm).



- Shift to remove inner feed rotor Assy .



3.8 Stator removal

- Block crankshaft with **ST-02**.

ST-02

- Remove bolts M10.
- Remove stator with tightening **ST-03** (M16 x P1.5).

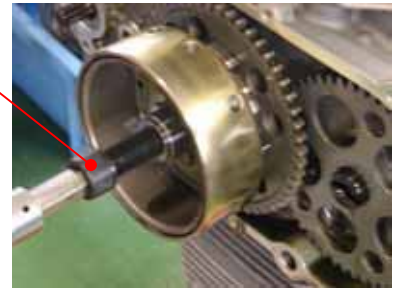
**ST-03**

- Remove woodruff key .



3.9 Starter idler gear and Driven gear removal

- Remove idler gear , idler shaft and 2 thrust washers .

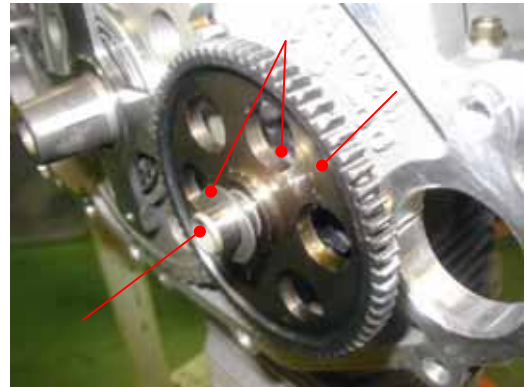

- Remove driven gear by turning clockwise (left).

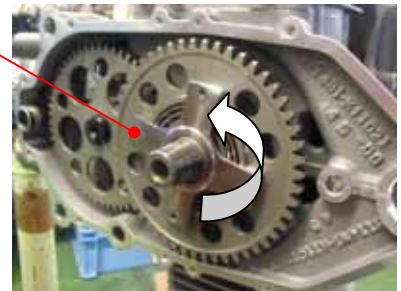

3.10 Flywheel removal

- Block crankshaft same as 1.8
- Remove 6 bolts M8.
- Shift to remove flywheel .



3.11 Cylinder head removal

- Remove 5 bolts M5 and cylinder head cover.
- Remove head cover gasket.

CAUTION: Do not damage contact surface!

- Rotate crankshaft to set piston to bottom dead center position.
- Remove bolt M5 and M6.



- Remove 4 nuts M8.
- Shift to remove rocker arm compartment.

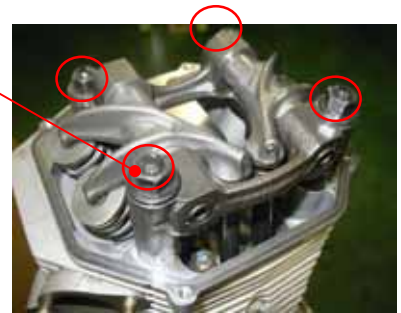

- Lift out push rods; stop oil dripping by sealing with finger.

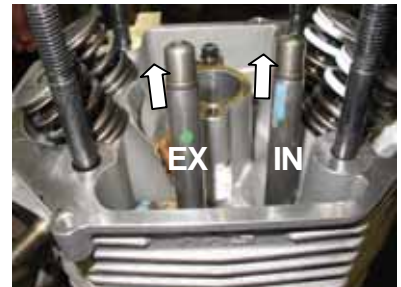

NOTE: Identify both push rods to IN / EX.

- Shift to remove cylinder head.
- Remove gasket .



3.11.1 Cylinder head disassembly

- Remove bolt M5 and banjo bolt M10.
- Remove oil jet pipe .

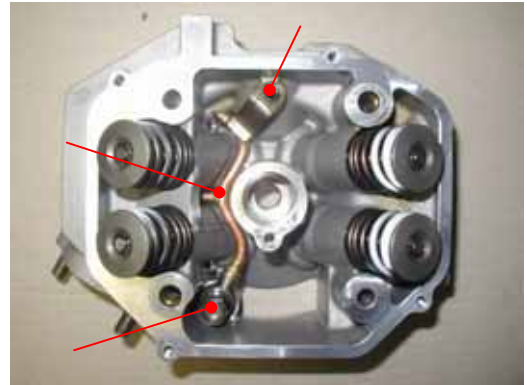

- Compress valve spring with valve spring mounting device and clamp or similar tool.
- Remove valve cotters and release valve spring.



- Remove valve spring retainer, valve springs and valve.

NOTE: To prevent damage to valve guide, trim out burrs which may be present on valve stems prior to the removal of valves.

- Remove valve spring seat.

3.12 Cylinder and Piston disassembly

NOTE: Identify both cylinders and pistons to RH/LH.

- Rotate crankshaft to set piston to top dead center position.
- Shift to remove cylinder. Support piston by hand to avoid damaging piston and piston rings.
- Remove gasket .



- Remove piston pin circlip using the specially shaped screwdriver.



- Pull out to remove piston pin.
- Remove piston.



CAUTION: Make sure to install rings in initial position.

- Remove piston rings using the piston ring pliers.
- Pull to remove hydraulic lifters from crankcase.



3.13 Crankcase disassembly

- Remove 2 bolt M6.



- Remove 8 bolts M6.
- Remove 2 bolts M8.
- Remove 4 bolts M10.

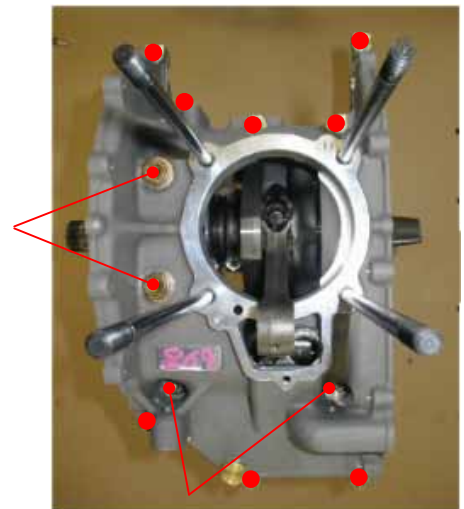

- Set crankcase on **ST-01**.
- Attach **ST-04** at mounting boss.

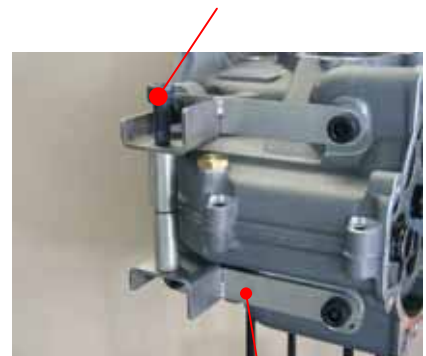
**ST-01****ST-04**

- Split crankcase with tightening bolt.

- Remove oil strainer.
- Remove camshaft.
- Remove crankshaft.
- Remove 4 thrust bearing .
- Remove 4 main bearing .

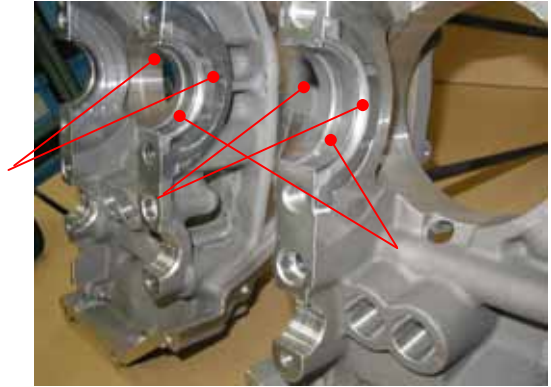

3.14 Crankshaft disassembly

- Remove 4 connecting rod bolts .
- Remove connecting rod cap end .
- Remove connecting rod bearing .

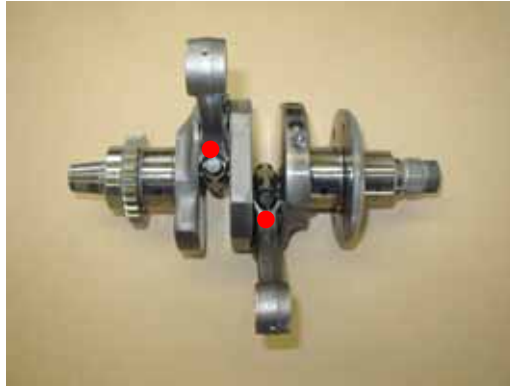

4 Assembly

4.1 Connecting rod reassembly

- Clean all parts.
- Fit connecting rod bearings . Apply motor oil to metal surface.

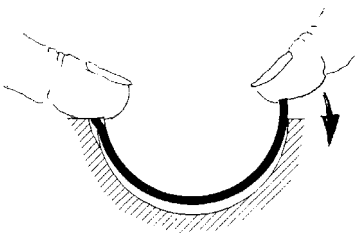

NOTE: Confirm the turn stop of bearing entered the ditch.

- Assemble connecting rod. Apply motor oil to bolt and thread.
- Tighten connecting rod cap end evenly with 2 connecting rod bolts. Tightening torque is 3.8 [kgfm].
- Swing connecting rod to check for ease movement.



CHANGE PARTS AT OVERHAUL: Connecting rod bearing (See para 6.1)

4.2 Crankcase reassembly

4.2.1 Crankshaft bearing and Thrust bearing

- Clean bearing seat and remove oil.
- Visually check the metal bearing surface. Remove oil from back of metal bearing.
- Place metal bearing into both crankcases.
- Place thrust bearing to crankcase with applying grease to back side of thrust bearing.

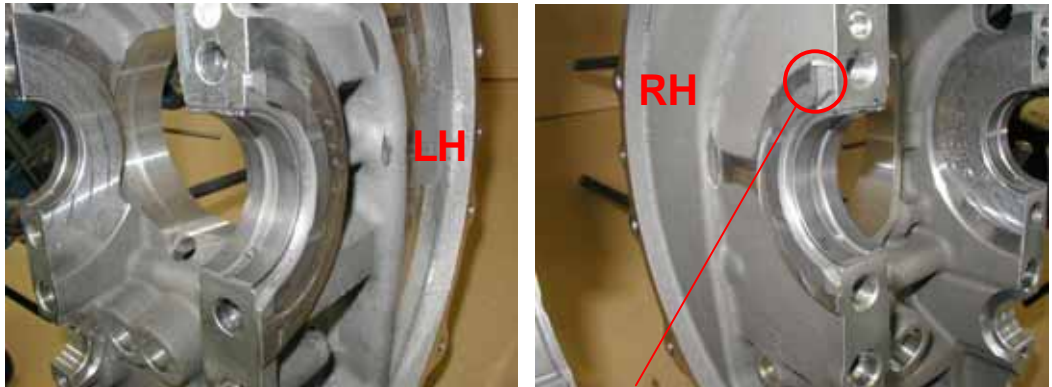

NOTE: There are two kinds of bearings. Bearing with a lug is attached to a RH side crankcase. Flat side of bearing is assembled to the crankcase side.

CHANGE PARTS AT OVERHAUL: Crankshaft bearing and thrust bearing (See para 6.2)

4.2.2 Crankshaft

- Apply motor oil to bearing surface.
- Place crankshaft to RH crankcase with care.

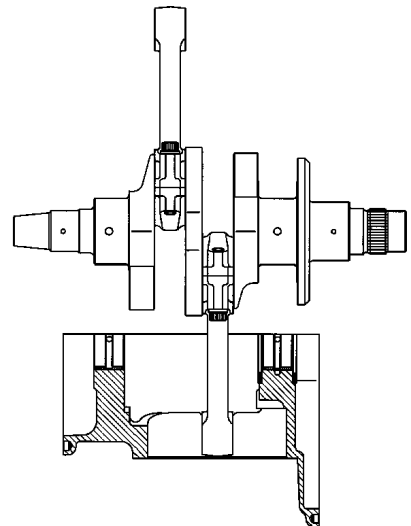

4.2.3 Camshaft

- Apply motor oil to camshaft journal and all teeth of drive and driven gear.
- Place camshaft to RH crankcase while uniting punch marks.



4.2.4 Oil strainer

- Fit **new** O-ring to oil strainer with applying motor oil.



- Place oil strainer to RH crankcase and tighten bolt M6-20 temporary.



4.2.5 LH crankcase

- Clean and remove oil from both contact surface of crankcase.
- Apply LOCTITE 5699 on contact surface of RH crankcase.
- Place 2 pipe knock-pins $\phi 8$ and 2 pipe knock-pins $\phi 15$.
- Place LH crankcase on RH crankcase.
- Fit washer and **new** O-ring to 2 bolts M10 with applying motor oil.

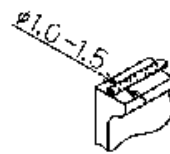
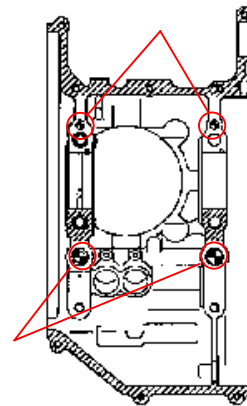

Around the thread boss

- Attach LH crankcase on RH crankcase with 2 bolts M10 (both upper side), 2 bolts M10 with O-ring (both lower side) and 2 bolts M8 applying motor oil to thread.

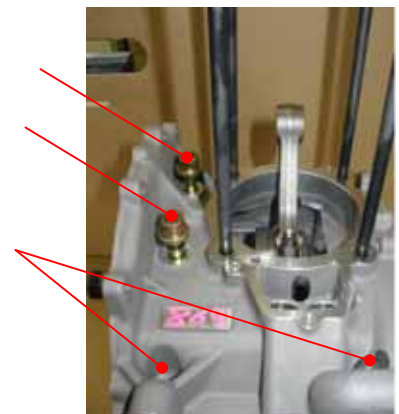

- Tighten 4 bolts M10 (both side) evenly to 4.8 [kgfm].
- Tighten 2 bolts M8 evenly to 2.4 [kgfm].
- Tighten 7 bolts M6-25 and 1 bolt M6-45 evenly to 1.2 [kgfm] with LOCTITE 243 and washers.
- Attach drain bolt with motor oil and **new** copper washer. Tighten to 1.2 [kgfm].

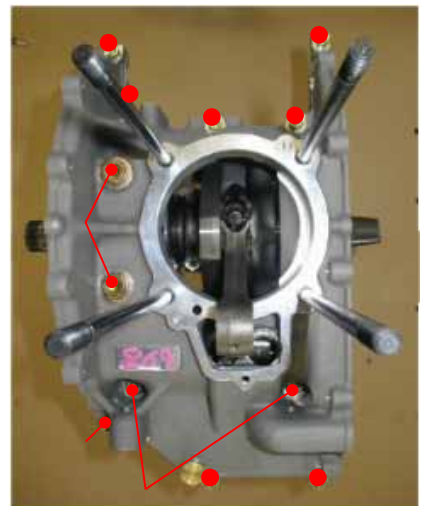

NOTE: The crankshaft and camshaft must turn freely.

- Wipe off the protruding LOCTITE.

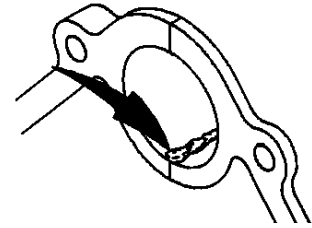

- Fix oil strainer with 2 bolts M6-20 with applying LOCTITE 243. Tighten to 1.2 [kgfm].



4.3 Piston reassembly

4.3.1 Piston ring

- Fit Top and Second rings using piston ring pliers, with the dot mark towards piston crown.

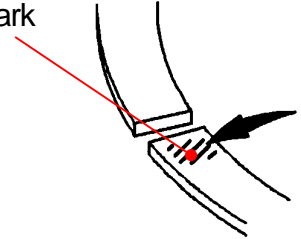

- Insert **new** piston pin circlip in groove of front marked (triangular sign) side.



- Apply motor oil over the whole of the piston pin, the bore in connecting rod and the bore in piston.
- Insert piston pin.



- Insert **new** piston pin circlip in another groove.



CHANGE PARTS AT OVERHAUL: Piston, piston pin, piston rings and piston pin circlip (See para 7)

4.4 Cylinder reassembly

4.4.1 Hydraulic lifter

- Fill hydraulic lifter with motor oil.
- Insert hydraulic lifter into crankcase with applying motor oil and MOLYPASTE .

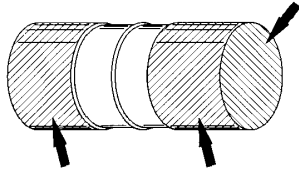

- Clean and remove oil from contact surface of crankcase and cylinder.
- Place **new** gasket to crankcase.



- 合口の位置

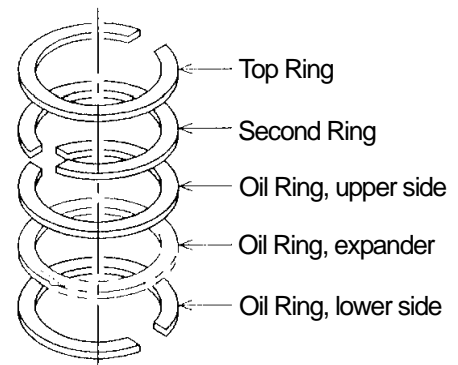

- Place pipe knock-pin 6.
- Lubricate piston and cylinder with motor oil. Compress rings with piston ring spanner and mount cylinder with care.



CAUTION: Use piston ring spanner to avoid ring breakage.

4.5 Cylinder heads reassembly

- Place valve spring seat on valve guide. Insert valve with MOLYPASTE, place valve spring and spring retainer in position.

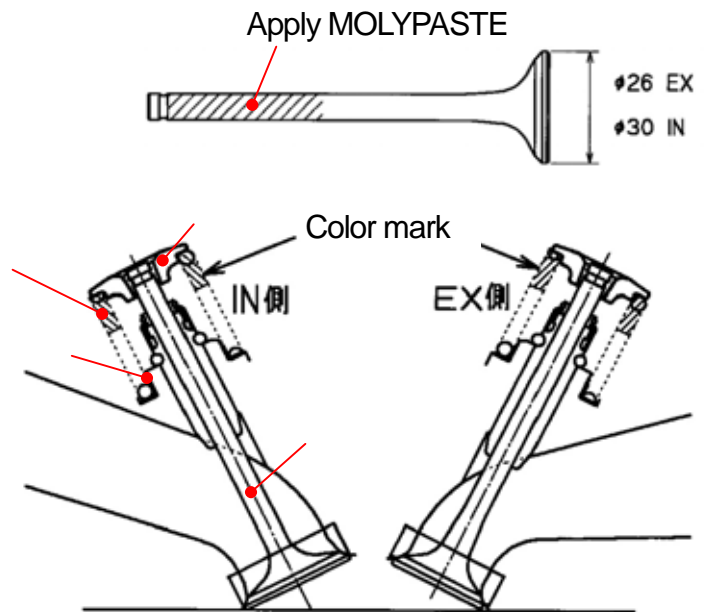

NOTE: Place valve spring with the color mark towards upper side.

CHANGE PARTS AT OVERHAUL: IN and EX valve

- Compress valve springs with valve spring mounting tool. Insert valve cotters and release springs.



NOTE: Check correct positioning of valve cotters.

- Push piston of banjo bolt to check for ease movement.



- Attach oil jet pipe to cylinder head with banjo bolt applying motor oil to thread. Tighten to 2.4 [kgfm].
- Insert bolt M5-10 with LOCTITE 243 and tighten to 0.8 [kgfm].

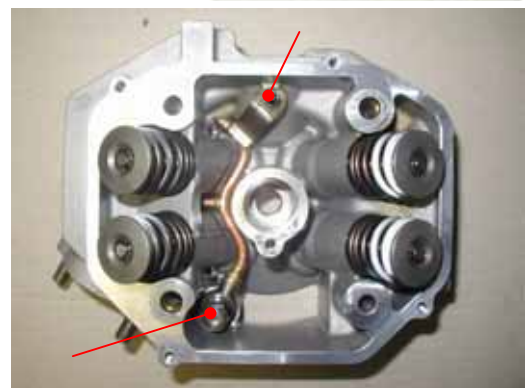

- Clean and remove oil from contact surface of cylinder and cylinder head.
- Place **new** gasket to cylinder.
- Place 2 pipe knock-pins 10.
- Place cylinder head.



4.5.1 Push rod

- Place push rod on hydraulic lifter.



NOTE: Coloring side is turned to cylinder head side.

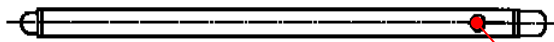

Color mark

- Check proper position of push rod.

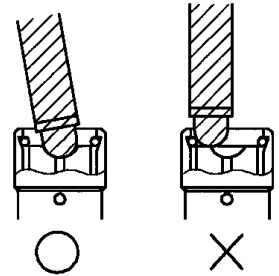

4.5.2 Rocker arm compartment

- Rotate crankshaft to set both lifters to bottom position.
- Place 2 pipe knock-pins 10.
- Attach rocker arm component to cylinder head with 4 nuts M8 and 4 washers applying motor oil to thread. Tighten evenly to 2.0 [kgfm].
- Tighten more 90 deg.

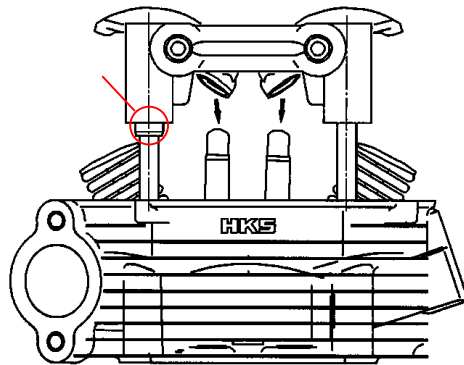

NOTE: Pay attention the direction of nut and washer.

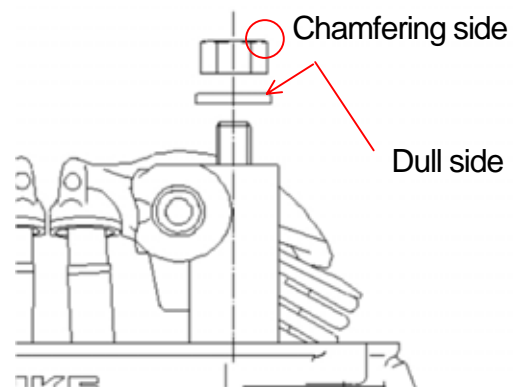

CHANGE PARTS AT OVERHAUL: M8 nut

- Tighten
bolt M6-20 to 1.2 [kgfm] and
bolt M5-20 to 0.8 [kgfm]
with LOCTITE 243 and washers.

NOTE: The valve must move freely when turning the crankshaft.



- Repeat same procedure from 2.3 on the opposite side.

4.6 Cylinder head cover reassembly

- Clean and remove oil from contact surface of cylinder head and cylinder head cover.
- Place **new** gasket to cylinder head.



- Attach cylinder head cover to cylinder head with 5 bolts M5-25 with LOCTITE 243 and washers. Tighten evenly to 0.8 [kgfm].

4.7 Flywheel reassembly

- Block crankshaft same as 1.8.
- Attach flywheel to crankshaft with 6 bolts M8-13 with LOCTITE 243. Tighten evenly to 2.4 [kgfm].



CHANGE PARTS AT OVERHAUL: M8-13 bolt

4.8 Driven gear and Starter idler gear reassembly

- Attach driven gear to crankshaft by turning to left. Apply motor oil over the whole of one-way clutch, bush bearing and gear tooth.

NOTE: The driven gear must engaged on crankshaft when turning **clockwise** (right) looking from rear side, and turn freely when turning **counter-clockwise** (left).

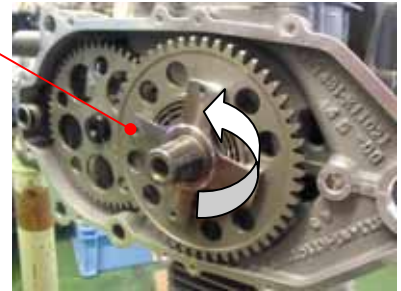

- Attach idler gear, idler shaft and 2 thrust washers applying motor oil.



4.9 Rear cover reassembly

4.9.1 Stator

- Attach woodruff key in crankshaft.
- Check for tight fit and degrease tapers of crankshaft and stator hub.

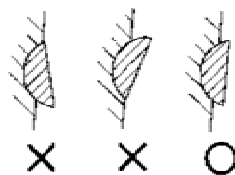

- Fit stator hub and washer Apply LOCTITE 243. to bolt M10-50 and tighten to 5.0 [kgfm].



4.9.2 Oil pump

- Attach inner feed rotor Assy and outer rotor in rear cover.
- Fit 4 **new** O-rings .
- Attach 2 knock-pins .

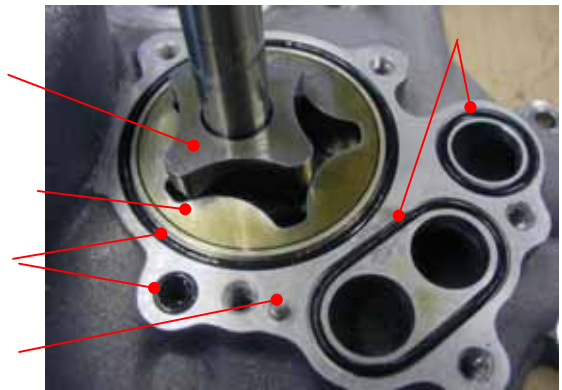

- Attach pump body (15mm).
- Attach woodruff key .



- Attach inner rotor (15mm).
- Attach outer rotor (15mm).
- Fit 2 **new** O-rings .
- Attach 2 knock-pins .



- Attach pump body (25mm).
- Attach woodruff key .



- Attach inner rotor (25mm).
- Attach outer rotor (25mm).
- Fit 2 **new** O-rings .
- Attach oil pump cover.



- Tighten oil pump with bolt M6-60, 4 bolts M6-110 and washers evenly to 1.2 [kgfm] applying LOCTITE243.

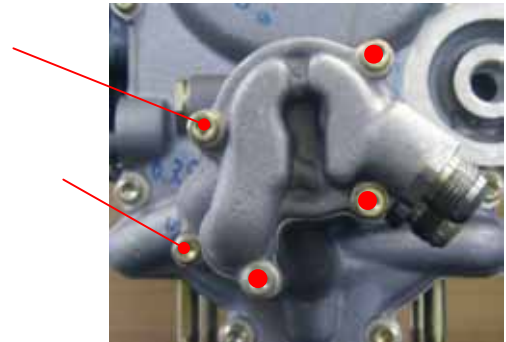

4.9.3 Pressure regulator

- Insert valve and spring applying motor oil.
- Attach bolt with **new** copper washer. Tighten to 2.5 [kgfm].

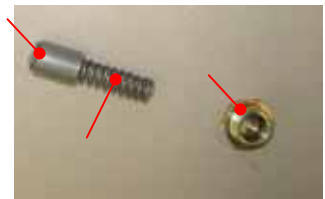

- Clean and remove oil from contact surface of crankcase and rear cover.
- Apply LOCTITE 5699 on red circle area.



- Place **new** gasket to crankcase.
- Place 2 pipe knock-pins 6.
- Turn oil pump shaft into a position to align with groove of camshaft.

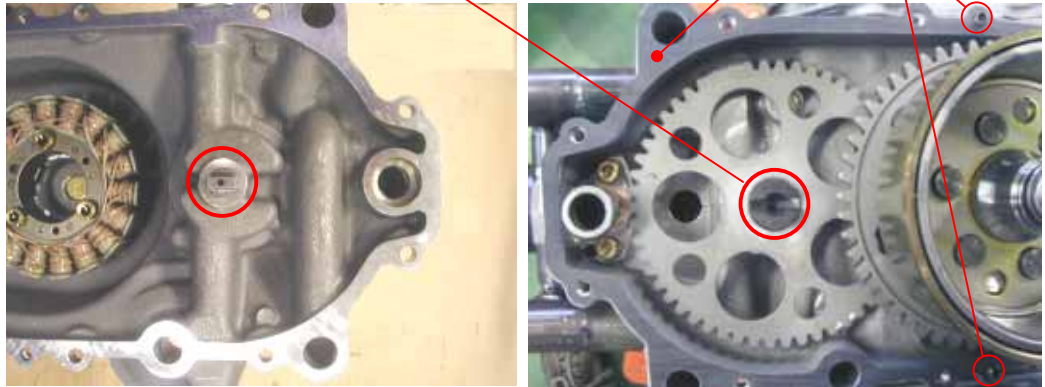

- Place rear cover on crankcase.
- Tighten rear cover with 10 bolts M6-20 and washers evenly to 1.2 [kgfm] applying LOCTITE 243.

4.9.4 Oil filter

- Lubricate the rubber seal of oil filter.
- Screw **new** oil filter by hand until it stops at the oil filter housing.
- Tighten by an extra 3/4 turn.

4.10 Front cover reassembly

- Clean and remove oil from contact surface of crankcase and front cover.
- Place **new** gasket to crankcase.
- Place 2 pipe knock-pins 6.
- Apply motor oil to bearing bush of front cover and crankshaft.
- Place front cover on crankcase.

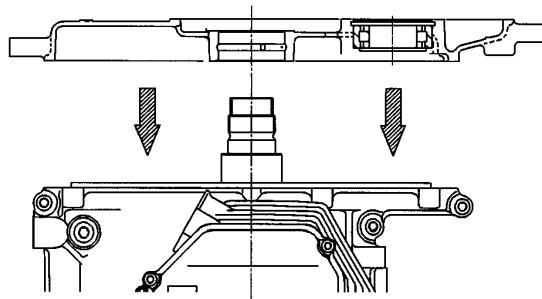
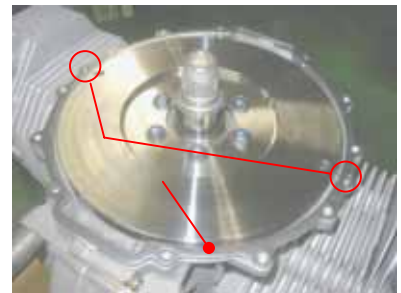

4.10.1 A type (ratio2.58)

- Tighten front cover with 12 bolts M6-30 and washers evenly to 1.2 [kgfm] applying LOCTITE 243

4.10.2 B type (ratio3.47)

- Tighten front cover with
 - 2 bolts M6-45,
 - 8 bolts M6-35,
 - 2 bolts M6-30 and washers evenly to 1.2 [kgfm] applying LOCTITE 243.



- Attach drive gear and washer to crankshaft.
- Tighten nut M25 to 10.0 [kgfm] applying LOCTITE 243.



Pay attention for the direction of the washer.

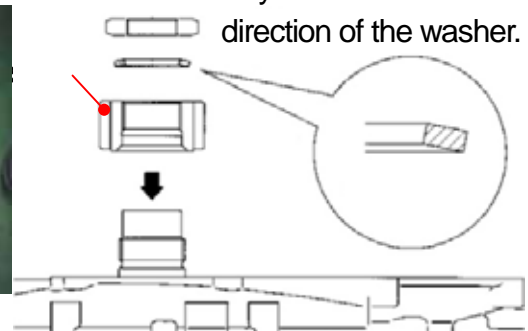

4.11 Gearbox reassembly

- Insert **new** oil seal from the inside, using insertion jig.
- Add seat PTO shaft with rounded side towards oil seal.
- Heat up gearbox in oven to approx. 120 °C.
- Press in ball bearing and fit circlip in the groove.

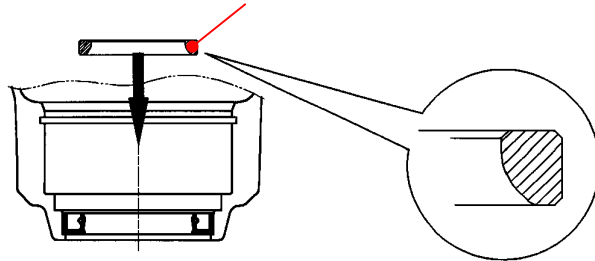

- Apply grease to sealing lips.
- Press PTO shaft from outside into gearbox.
- Attach spacer .



- Attach 12 spring washers on the shaft as illustrated.

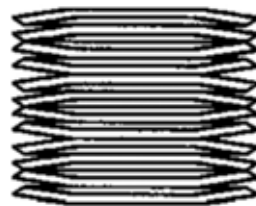

- Attach hub dog .
- Attach gear so the knuckle joint is engaged to new face of hub dog .



- Attach retainer .



- Compress gear using **ST-07** and attach half rings with the flat side out.

ST-07



- Set inner race with **ST-09**.
Press **ST-07** to insert inner race.

ST-09

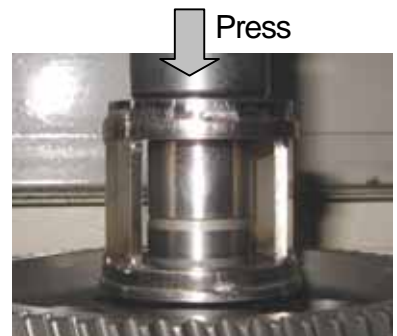

- Fit circlip in the groove.



- Clean and remove oil from contact surface of front cover and gearbox.
- Place **new** gasket to front cover.
- Place 2 pipe knock-pins 6.
- Apply motor oil to roller bearing and gear tooth.
- Place gearbox on front cover.

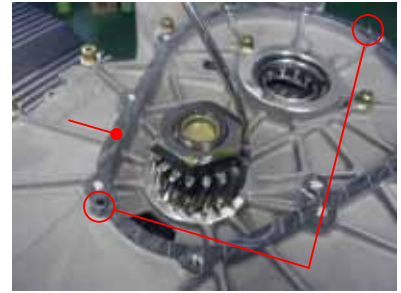

4.11.1 A type (ratio2.58)

- Tighten gearbox with
4 bolts M6-25,
4 bolts M6-45 and
washers evenly to 1.2 [kgfm] applying LOCTITE 243.

4.11.2 B type (ratio3.47)

- Tighten gearbox with
4 bolts M6-25,
6 bolts M6-45 and
washers evenly to 1.2 [kgfm] applying LOCTITE 243.

4.12 Electric starter reassembly

- Apply motor oil to gear tooth and installation bore. Fit electric starter into crankcase.



- Tighten electric starter with 2 bolts M6-35 and washers to 1.2 [kgfm] applying LOCTITE 243.



4.13 Spark plug reassembly

- Insert spark plug with LOCTITE ANTISEIZE and tighten to 2-3 [kgfm].

CHANGE PARTS AT OVERHAUL: Spark plug (Replace every 200Hr)

4.14 Intake manifolds reassembly

- Clean and remove oil from contact surface of cylinder head and intake manifold.
- Place **new** gasket . The seal spreading side is assembled to manifold side.
- Tighten intake manifold with 2 bolts M8-20 to 2.4 [kgfm] applying LOCTITE 243.

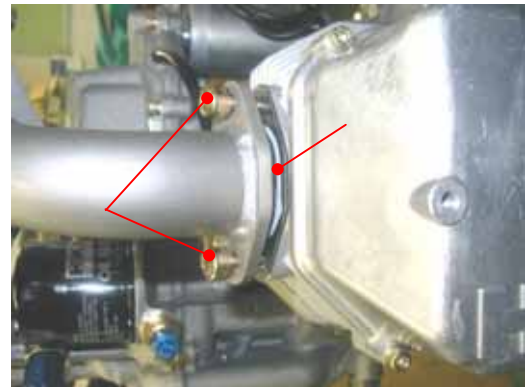

4.15 Carburetors reassembly

- Attach carburetor by turning action and tighten clamp screw

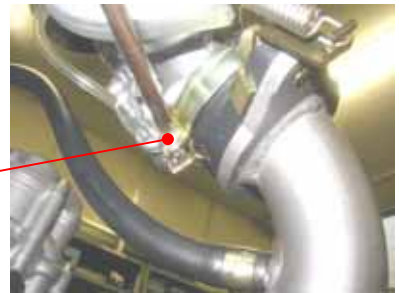

CHANGE PARTS AT OVERHAUL: Insulator rubber

4.15.1 Upper type

- Tighten 2 nuts M6.



4.15.2 Horizon type

- Hook tension spring.



5 Table for torque values

Designation	Size	Torque [kgfm]	Remark
Connecting rod	M8	3.8	Engine oil
Flywheel	M8	2.4	LOCTITE 243
Drive gear (nut)	M25	10.0	
Crankcase	M10	4.8	Engine oil
	M8	2.4	LOCTITE 243
	M6	1.2	
Cylinder - Crankcase	M6	1.2	LOCTITE 243
Oil jet pipe - Cylinder head	M10 (Banjo)	2.4	
	M5	0.8	
Stud bolt - Crankcase	M8	2.0	Engine oil
Rocker arm component (nut)	M8	2.0 + 90 [deg]	
Cylinder head - Cylinder	M5	0.8	LOCTITE 243
Cylinder head cover	M5	0.8	
Front cover	M6	1.2	
Gear box	M6	1.2	
Starter motor	M6	1.2	
Stator hub	M10	5.0	
Oil strainer	M6	1.2	
Adapter M14 (rear cover)	M14	3.0	
Drain bolt	M10	1.2	
Union (rear cover)	M18	3.0	
Rear cover	M6	1.2	LOCTITE 243
Regulator bolt	M18	2.5	Engine oil
Oil pump	M6	1.2	LOCTITE 243
Stud bolt (Exhaust port)	M8	2.0	LOCTITE 271
Spark plug	M14	2.0 - 3.0	LOCTITE ANTISEIZE
Intake manifold	M8	2.4	LOCTITE 243
Insulator rubber	M8	2.4	

6 Selection of metal bearing

6.1 Connecting rod bearing

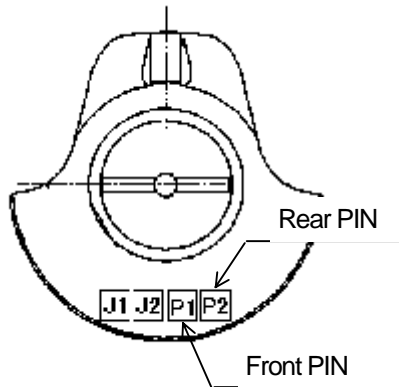

No. on P1/P2		O.D of pin [mm]
N₁	1	40.994 ~ 41.000
	2	40.988 ~ 40.993

No. on con-rod		I.D of journal [mm]
N₂	1	44.000 ~ 44.008
	2	44.009 ~ 44.016

N ₁ +N ₂	Color of bearing
2	BROWN
3	BLACK
4	BLUE

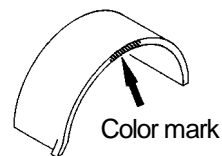

6.2 Crankshaft bearing

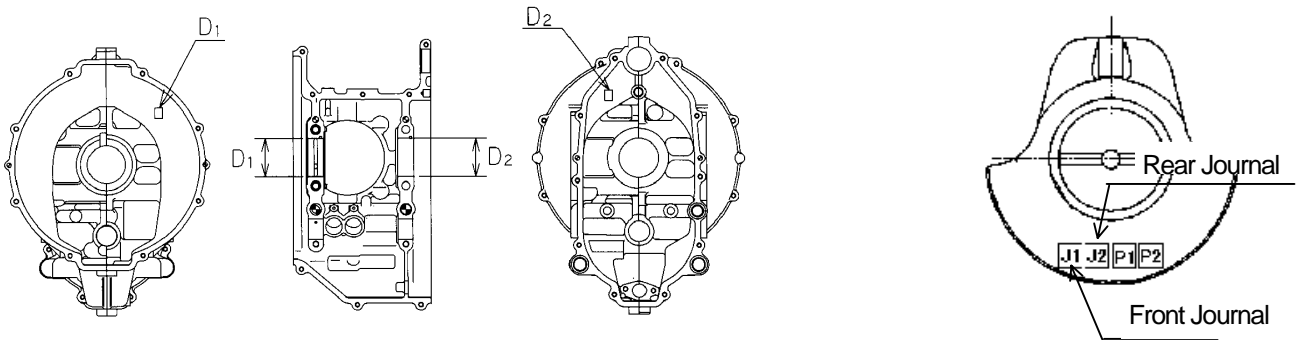

No. on D1/D2	I.D of journal [mm]	
N ₁	1	49.000 ~ 49.006
	2	49.007 ~ 49.012

No. on J1/J2	O.D of journal [mm]	
N ₂	1	44.994 ~ 45.000
	2	44.988 ~ 44.993

N ₁ +N ₂	Color of bearing
2	BROWN
3	BLACK
4	BLUE

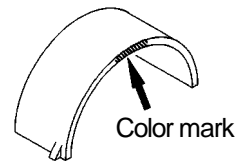

7 Grading of cylinder and piston

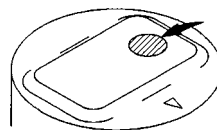
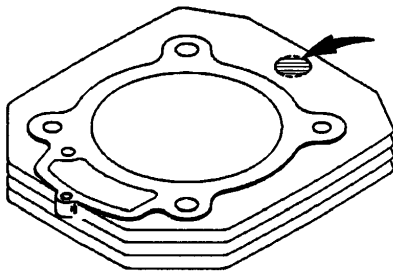

Grading letter (A, B, C) is marked as illustrated. Use same grading of cylinder or piston when replacing.

Grading	Cylinder Bore [mm]	Piston O.D [mm]
A	84.985 ~ 84.994	84.970 ~ 84.979
B	84.995 ~ 85.005	84.980 ~ 84.990
C	85.006 ~ 85.015	84.991 ~ 85.000

8 Wear limits

Designation		New [mm]	Wear limit [mm]	
Cylinder/Piston				
See Para 7				
Piston pin				
Piston pin		19.996 - 20.000		
Piston pin bore		20.002 - 20.008		
Clearance, pin in piston		0.002 - 0.012		
Con-rod bore, small end		20.007 - 20.012		
Clearance, pin in con-rod		0.007 - 0.016		
Piston rings				
Top ring				
Ring/groove clearance		0.050 - 0.085		
Ring end gap		0.100 - 0.200		
Second ring				
Ring/groove clearance		0.025 - 0.060		
Ring end gap		0.150 - 0.250		
Cylinder head				
Wear on valve seat				
Valve guide bore		6.000 - 6.009		
Valve stem	IN	5.970 - 5.985		
	EX	5.960 - 5.975		
Stem clearance	IN	0.015 - 0.039		
	EX	0.025 - 0.049		
Sealing face width, IN valve			2.40	
Sealing face width, EX valve			2.40	
Out-of-true on valve head				
Valve spring, free length		38.78		
Rocker arm bore		12.024 - 12.042		
Rocker arm shaft		11.990 - 12.000		
Rocker arm, radial clearance		0.024 - 0.052		
Rocker arm, axial clearance		0.100 - 0.450		
Crankshaft				
See Para 6				
Axial clearance		0.200 - 0.390		

Designation		New [mm]	Wear limit [mm]	
Crankcase				
See Para 6.2				
Lifter hole bore	- S/N100895	21.440 - 21.460	21.480	
	S/N100896 -	21.414 - 21.434	21.460	
Propeller gearbox				
Prop flange, axial out-of-true				
Wear depth of dogs			0.20	
Disk spring, free length		4.05 - 4.65	3.80	
Camshaft				
Axial clearance		0.100 - 0.250	0.30	
Oil pump				
Plunger, axial clearance		0.030 - 0.070	0.120	
Push rod				
Out of round		0.0 - 0.1		

